

!!!! IMPORTANT!!!!

A123 M1 Cell is a related safe and stable product compare with Li-Po and Li-ion technology. However, the A123 charging adapter (A123 Daptoer) requires you to pay some attention to what you are doing. It's possible to damage your battery pack if you do wrong operation. You are ultimately responsible for what happens to your pack and whatever might catch fire nearby. DO NO leave charging cells unattended!

注意:

A123 M1 電池相對於鋰聚合/鋰離子電池來說，是一種相對安全的技術。然而，嚴重的操作錯誤仍然可能造成你的電池損壞甚至引發火在等潛在危險。你必須對於使用這項產品所造成的結果負責。建議在充電的時候能夠隨時注意並且遠離易燃物。

Factory:

It's a small circuit board which you can use it with your LiPo/Li-ion charger even power supply to charge A123/M1 cell.

- Handles DeWalt 36V (M1) cells
- Handles A123 Systems (M1) cells
- Adapts LiPo chargers for M1 cells
- Adapts NiCd/NiMh chargers for M1 cells
- Handles voltage up to 12 M1 cells in serial
- Handles up to 20 amps (suggest using cooling fan for current over 8 amps)

Specifications:

Size: 25mmx35mm

Support Cell Number: 2~12 cell Li-Fe.

Charge current: Up to 7A without cooling/ 20A with cooling fan.

Cut off voltage: 3.7v/cell

Panel description:

面板說明:

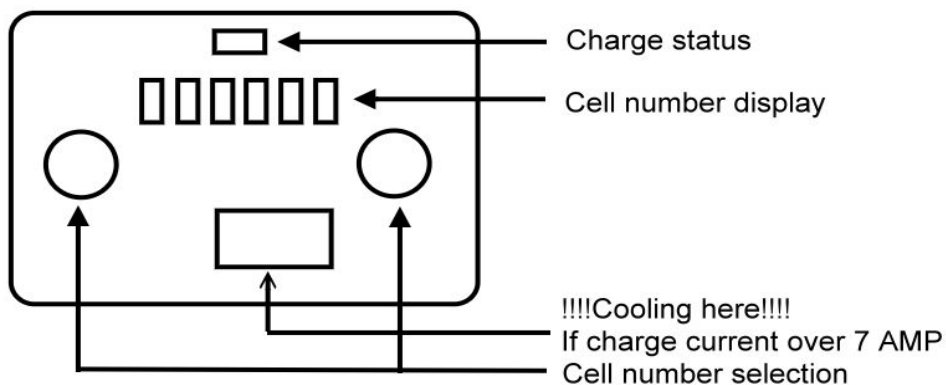
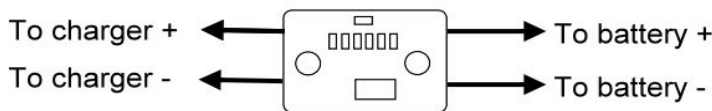

Charge status:

This LED is on when the voltage of battery pack lower than cut off voltage.

顯示充電情況,當燈號發亮的時候,表示為開,反之為關

Cell number display:

燈號顯示

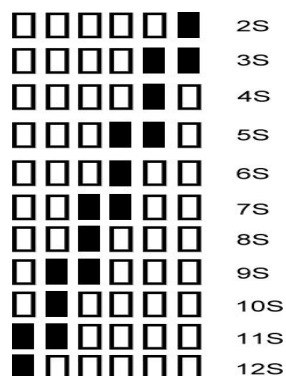

The LEDs indicate selected cell number.

燈號顯示目前所選擇的 Cell 數目。

Setup procedure:

使用方式

1. Connect the charger to the CHGR wires, connect the battery pack to the BATT wires.
先將 Daptoer 接到充電器上,另一端接到電池。
2. Using the “Cell number selection buttons” to select the number of cells (in serial). Press left button to increase the cell number, press the right button to decrease the cell number.
使用 Cell number selection buttons 選擇連接到 Daptoer 上 A123 電池的種類。左邊按鈕為增加電池的串數,右邊為減少。
3. This step depends on the type of charger you used:
 - 3.1 If your charger support Li-Po/Li-ion mode, Please read the instruction as below:
如果你的充電器為鋰電池充電器; 設定充電器的充電模式,參考表如下

Li-Po Mod

Daptoer 顯示 Cell No.	Cut off voltage of A123	Cell Select	Cut off voltage of Li-Po	Diff.	Diff. pre cell
2	7.2	2	8.4	1.2	0.60
3	10.8	3	12.6	1.8	0.60
4	14.4	4	16.8	2.4	0.60
5	18	5	21	3	0.60
6	21.6	5	21	-0.6	-0.10
7	25.2	6	25.2	0	0.00
8	28.8	7	29.4	0.6	0.08
9	32.4	8	33.6	1.2	0.13
10	36	9	37.8	1.8	0.18
11	39.6	10	42	2.4	0.22
12	43.2	11	46.2	3	0.25

Li-ion Mod

Cell No.	Cut off voltage of A123	Cell Select	Cut off voltage of Li-ion	Diff	Diff. pre cell
2	7.2	2	8.2	1	0.50
3	10.8	3	12.3	1.5	0.50
4	14.4	4	16.4	2	0.50
5	18	5	20.5	2.5	0.50
6	21.6	5	20.5	-1.1	-0.18
7	25.2	6	24.6	-0.6	-0.09
8	28.8	7	28.7	-0.1	-0.01
9	32.4	8	32.8	0.4	0.04
10	36	9	36.9	0.9	0.09
11	39.6	10	41	1.4	0.13
12	43.2	11	45.1	1.9	0.16

There are several types of Li-Po/Li-ion charger in the market:

目前市售的 Li-Po/Li-ion 充電器大致分為以下幾種類型

1. Selective cell number of Battery Pack
Battery Pack 的 cell 數量可以選擇
2. Un-selective cell number of Battery Pack
Battery Pack 的 cell 數量不可選擇
 - a. Auto-detective and Un-selective (**Do not use**)
自動偵測且不可選擇 (**不可使用**)
 - b. Fixed cell number
固定 cell 數量
3. Balance Charger (e.g. Align RCC-4CX)
平衡式分壓充電器

We DO NOT recommend using Li-Po/Li-ion charge mode on 2~5S of A123 Pack. The cut off voltage of A123 cell is 2V while Li-Po/Li-ion has cut off voltage at 3V. This means that the voltage of an un-charged 2~5 A123 pack could be much lower than LiPo/Li-on and the charger won't engage the charging process due to WRONG CELL COUNT DETECTED. For 6S and above A123 Pack, you can select proper cell number (see the table above) to fool the charger.

2~5S 的 A123 Pack 並不適合選用 Li-Po/Li-ion。因為電池電量用完可能每 cell 會低於 3v。高階充電器在這時候常常會產生警告並且停止充電。

More tests of Balance Charger are under going. Base on the specifications and technical report of A123, we know that Li-Fe cell can handle maximum 4.2v cut-off voltage without damage. Please follow the following steps, you can safely charge A123 pack on Balance Chargers.

第三種 Balance Charger 目前正在進行更多的測試。按照 A123 所提供的技術資料，Li-Fe 電池最大可以承受到 4.2 的截止電壓且不會損壞。目前已知在以下情況下是可以直接使用。

1. Please make sure that the charger cut-off voltage is under 4.2V according to the specifications of Li-Po/Li-ion battery. You can find the information on your charger user's manual.
確認充電器的截止電壓是符合 Li-Po/Li-ion 的規格規範。
2. Disconnect the battery and charger immediately when your charger shows "full charge". DO NOT leave your battery on charger

overtime. According to the A123 M1 test result, the voltage will increase fast when it's over 3.6v and drop down after cut off. Most Balance Chargers will stop charging when it detects the voltage over 4.2V. But some chargers will be re-engaged if the voltage drops below 4.2V.

當電池充飽後立刻取下，不長時間持續接在充電器上。參看原廠提供規格資料，Li-Fe 電池超過 3.6v 之後，電壓會很快的上升，大多數的充電器偵測到達到充電截止電壓後會停止充電，然而部分充電器還會持續偵測，當發現電池電壓下降之後會恢復充電。因此不可以長時間接在充電器上。

3. We didn't find any Balance Charger had low voltage cut off functionality by far. If your charger can't be worked when the voltage lower than 3V, please report to us.

當然，也有可能有些充電器有 3V 以下的低電壓保護而導致無法使用，但是我們目前測試過的機器都沒有類似的功能。如果有發現歡迎隨時回報。

From the table above you can see that 7S A123 pack is perfectly matched with 6S Li-Po charge mode. For other configurations, the battery pack may not reach its full capacity after A123 Daptoer cut off. Please charge the pack again by using a lower charging current (as low as you can select) to get best performance.

上述表格為設定充電器 cell 數量的對照表。由表格中我們可以知道 7S 的 A123 電池選用 6S 的 LiPo 模式可以完美的配合。至於其他的模式，建議在顯示充飽或者是 A123 Daptoer 切斷後，再選用最小的充電電流再充電一次，已達到最佳的效果。

Note:

1. If your charger doesn't specify Li-Po/Li-ion mode or couldn't be recognize, please refer to Li-Po mode.
如果你的充電器並沒有區分 Li-Po 或是 Li-ion 模式的話，請參考 Li-Po 模式。
2. We recommend using Balancer with A123 battery pack. Please read "Battery Balance" section for more details.
建議搭配平衡器使用，細節請參看"電池平衡"內容。

- 3.2 If your charger supports Ni-Cd/Ni-Mh mode:

There are several different types of Ni-Cd/Ni-Mh charger we can find on market.

目前市售 Ni-Cd/Ni-Mh 充電器有以下幾種類型

1. Auto-detective cell number and the adjustable current setting.
自動偵測 cell 數量，並且可以設定充電電流
2. Fixed cell number (**Do not use**)
固定 cell 數量 (**不可使用**)
3. Please contact us if there is other type of charger.
其他類型請提供資料讓我們分析

Please charge the battery in 2A charging current once. Then decrease the charging current to 0.2A and charge again after A123 Charging Adapter cut off. The battery can be charged about 95% full.

請使用 2A 充電電流先充電一次，當 A123 Charging Adapter 切斷之後，再使用 0.2A 或者是小電流再充電一次。大約可以充飽到 95%~98%以上。

- 3.3 You may use DC power supply to charge the battery pack directly, however, please make sure you are familiar with A123 M1 cell specification and with sufficient electric knowledge.

如果你要用 Power supply 搭配，請詳細閱讀最後的技術資料，並且建議具備足夠的電工相關知識的使用者適用。

經過我們測試最安全的操作方式如下：

1. Please use the power supply with adjustable output voltage and current limited functions. The output current may over 10A.
選用可以調整輸出電壓以及電流限制功能的 Power Supply。提供電流需大於 10A 以上。
2. Adjust the output voltage to the cut off voltage of your battery pack. (e.g. 3.6V times cell number)
將輸出電壓調整到需要充電的 Pack 的充電截止電壓。(即 3.6V * 串數)
3. Connect the battery pack with A123 Dapoter, limit the max output current to 10A. Take off when the current lower than 0.1A or

after 1 hr.

將電池以及 A123 Daptoer 連接好，充電到電流顯示極低的時後取下即可。

Note:

- a. The cut off voltage of A123 Daptoer is 3.7V which is a little bit higher than A123 specs. If the supplied voltage is lower than (3.7V * cell), the A123 Daptoer may not cut off during the charging process. However, this won't be a problem as the battery will never excess the supplied voltage which is save (lower than 3.7V per cell).

A123 Daptoer 的斷電電壓為 3.7V 的倍數。略高於規格書，因此如果你的電源電壓低於他的電壓，則 A123 Daptoer 可能不會斷電。但並不造成任何影響。

- b. Please DO NOT charge the pack over one hour.

以上述方式充電，充電時間勿超過 1hr。

Battery balance:

電池平衡:

During charging procedure, the voltage of A123 cell rises very quickly after reaching 3.5~3.6V. The voltage increase rate depends on the inner-resistance and charge feature of each cell. We highly recommend choosing A123 pack with well inner-resistance matching and cell capacity matching products, such as A123 battery pack from A123 Packs Co., LTD. Products.

After fast charging the battery pack, or a lot of charge/discharge cycles, the voltage difference will become conspicuous. This has no safety issue but the battery might not perform at its best. We highly recommend charging A123 battery with balancer.

A123 電池充電到 3.5~3.6v 之間的時候，電壓會上升的很快。而上升的速度又會根據每個 cell 的特性不同而略有差異。因此我們強烈建議選用 A123 Battery Pack 的時候，要選擇有做電池內阻以及容量配對的產品，例如 A123 Packs Co., LTD.的產品。

然而長時間使用或者是常常使用大電流的快速充電，會很容易增加每個 cell 之間充電容量的差異。經過多次測試，是不會對 A123 電池的 cell 造成損壞或是導是災難。但可能會影響整個 Pack 的表現。因此我們強力建議搭配平衡器來使用 A123 Daptoer 以及 A123 電池。

Specification of A123 M1 Cell

Nominal voltage 3.3V

Nominal capacity 2.3Ah

Nominal dimensions 26mm ϕ x 66.5mm ht.

Nominal cell weight 70g

Cell charging parameters: CC-CV (constant current – constant voltage)

Recommended charge current (0°C to 60°C ambient temp): 3A

Recommended charge voltage: 3.6V

Recommended float charge voltage: 3.45V

Recommended cut-off current for CV hold (indicating 100% SOC): 0.05A

Maximum continuous charge current (20°C to 60°C ambient): 10A

Maximum allowable charge voltage: 4.2V MAX

Fast charge time: 15 minutes

Cell discharging parameters (-30°C to +60°C ambient temperature)

Recommended discharge cut-off voltage: 2.0V

Maximum continuous discharge current: 60A

Cell temperature parameters (skin temperature)

Maximum recommended cell temperature: 70°C

Maximum allowable cell temperature: 85°C

Allowable storage temperature range: -50°C to +60°C

Recommended charge method: CC-CV

The cell should be charged at the recommended charge current until the normal charge voltage is reached. Apply a constant voltage hold at the recommended charge voltage until the cut-off current for CV hold is reached (or 30 minutes, whichever comes first). The cell will be charged to 100% SOC.

Recommended fast charge method

Charge the cell at the maximum continuous charge current until the maximum recommended charge voltage is reached. Apply a constant voltage hold at the maximum recommended cell voltage until the total charge time reaches the fast charge time. The cell will be charged to over 96% SOC. Fast charge should not be attempted outside the recommended temperature range and should be stopped if the cell exceeds the maximum allowable cell temperature.